

8000 Multi-Purpose Islands

Description:

Mobile outdoor Ipe (ironwood) cabinet housing granite counter-top work area, locking sliding doors, and with accessory options for adjustable height shelves and/or drawers, sinks, ice bins, refrigeration, beverages, waste and recycle bins.

Standard Features:

- Solid ipe hardwood construction
- Heavy duty 4"x2" casters
- Locking front casters
- Locking sliding doors
- Storage slot for sliding doors
- Granite counter tops
- Counter-top access grommets

Specifications:

Unit dimensions:

- Length - 80 3/4"
- Width - 31"
- Height - 40 3/4"
- Weight - 1000 Lbs.

Crated for shipping dimensions:

- Length - 89"
- Width - 39"
- Height - 50"
- Weight - 1300 Lbs.

Accessories & Options:

- Adjustable internal drawers & shelves
- Ice & Water Fill Station
- Sink
- Self Contained Hot & Cold Water
- Self Contained Cold Water
- Refrigerator
- Cups and Cold Drawers
- Counter top waste bucket with lid
- Counter top waste chute with lid
- Waste / recycle bins
- Umbrella Holder
- Swinging doors
- Solid surface material counters

Model 8000-S4-S4-S4 shown

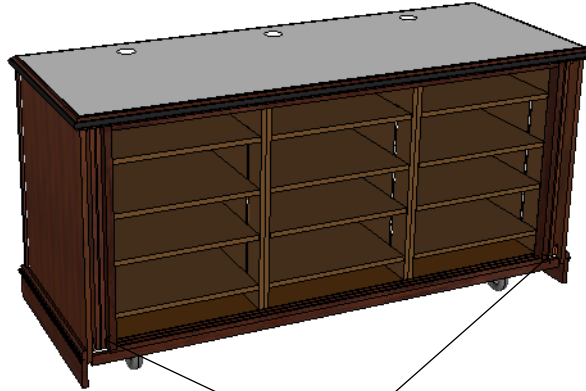

Shown with doors closed

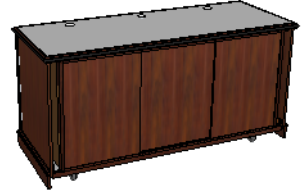

Sliding door storage slots

Front View

Top View

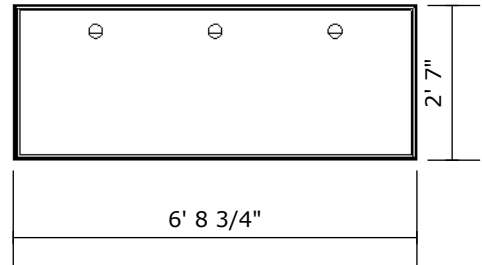
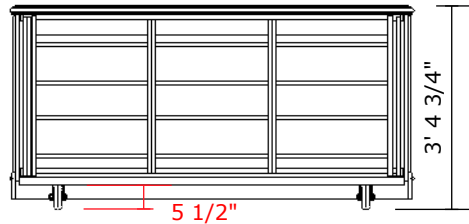

Back View

Side View

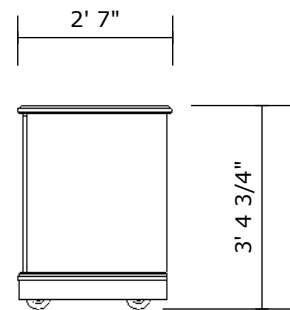
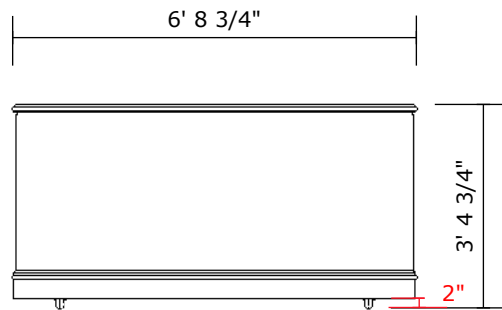

8000 Multi-Purpose Islands

Configure Model Options

Start with an empty 8000 Island (left) and configure it to meet your needs from the standard modular options below. Write the module codes for the corresponding position in the SKU # by making the following choices:

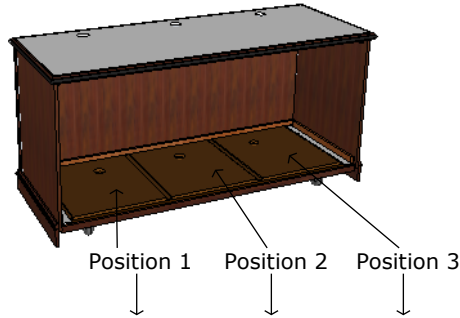

- 1) Choose position 1 module
- 2) Choose position 2 module
- 3) Choose position 3 module

8000- _____ - _____ - _____ Island

1) Choose position 1 module

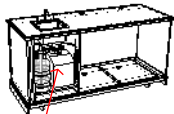

8000-SHCW- _____ - _____

2) Choose position 2 module

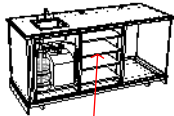

8000-SHCW-S4- _____

3) Choose position 3 module

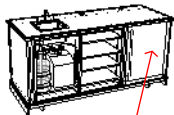

8000-SHCW-S4-REF

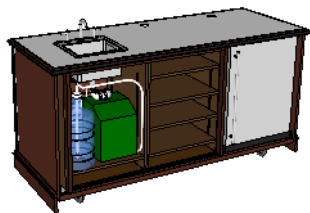

8000-SHCW-S4-REF

Configuration Modules

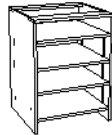

S4 - Shelf module with 4 adjustable shelves

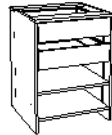

DS - Drawer & shelf with 2 adjustable drawers & 2 adjustable shelves

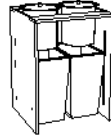

TRB or TRC - Recycle and waste bins with counter top buckets (B) or chutes (C)

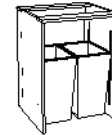

TR - Recycle and waste bins

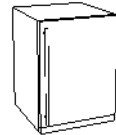

REF - 5.5 cu ft stainless steel refrigerator - Works best in position 3

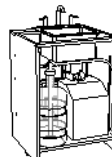

SHCW - Sink with self-contained hot and cold water (HCW)

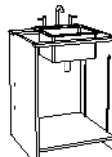

S - Sink

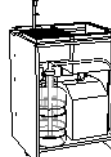

IWCW - Ice & water fill station with self-contained cold water (CW)

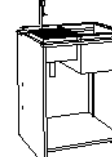

IW - Ice & water fill station

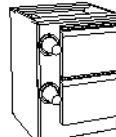

CD - Ice cooled stainless steel cold drawers (2) & cup dispensers (2)

| Item Code | Description |
|-----------|---|
| 8000 | 80" Island |
| S4 | Shelf module |
| DS | Drawers & shelves module |
| TRB | Trash & recycle bins with countertop buckets |
| TRC | Trash & recycle bins with countertop chutes |
| TR | Trash & recycle bins |
| S | Sink |
| SHCW | Sink with self-contained hot & cold water |
| IW | Ice & water fill station |
| IWCW | Ice & water fill station with self-contained cold water |
| CD | Cup dispensers (2) & cold drawers (2) |
| REF | 5.5 cu. Ft. stainless steel refrigerator |
| SOL ** | Upgrade to solid surface counters |
| SWD ** | Upgrade to swing doors |
| VC ** | Vinyl Cover |
| UB ** | Market Umbrella Holder Bracket |

** Add code to end of item SKU #

8000 Multi-Purpose Islands

Mechanicals Access

All wait stations come with a 15 Amp 120V GFCI outlet with 9' cord and NEMA 5-15 plug type in the cabinet.

Counter tops have 2" access grommets for electric and data cables.

Access grommets are provided in the base of all units at fixed intervals for easy access to electrical, data and plumbing connections.

End user is responsible for final connections.

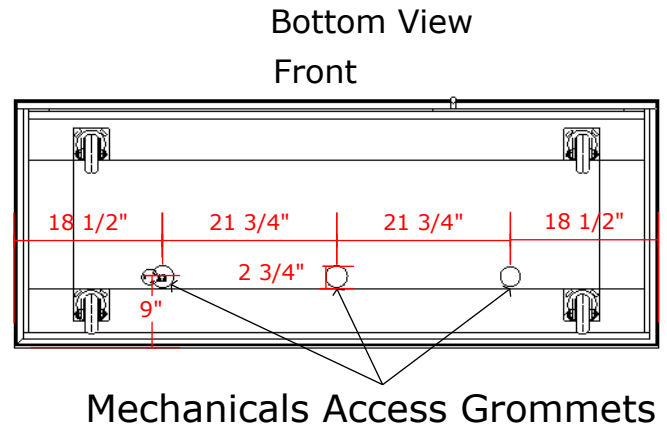
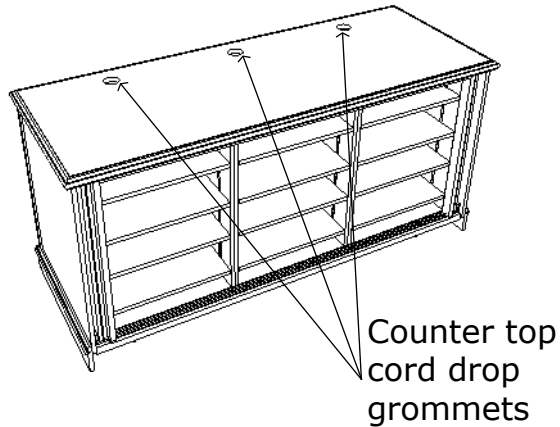

Shop Drawings - OK for production

Approved _____

Date _____